

| REV | ECO | DESCRIPTION | DATE | BY | APPD |
|-----|------|--|-----------|----|------|
| C | 3656 | CORRECT MOUNTING HOLE SIZE AND HARDWARE KIT. | 3/15/2013 | CK | JK |

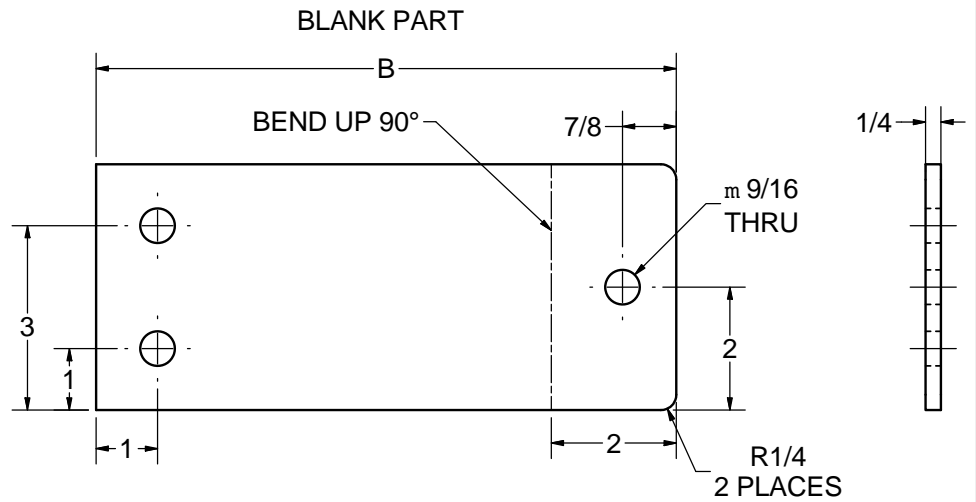
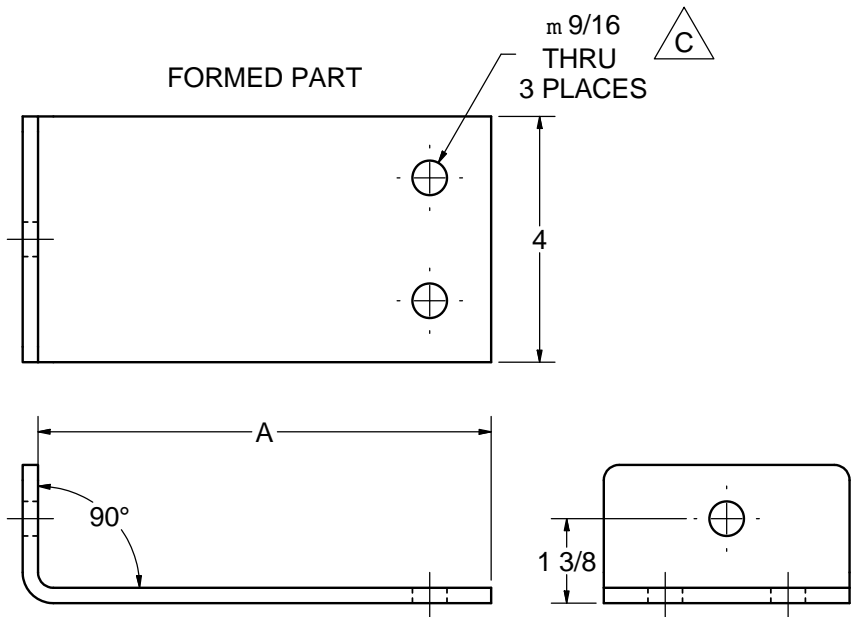

RAW MATERIAL: A-302-0727 1/4 X 4 HR FLAT
SEE D0570319 FOR KIT

| PART NO. | DESCRIPT | A | B | O.A.L. |
|----------|----------|--------|--------|----------|
| SF9275 | 7 | 7 3/8 | 9 3/8 | 0.78125 |
| SF9276 | 8 | 8 3/8 | 10 3/8 | 0.864583 |
| SF9277 | 9 | 9 3/8 | 11 3/8 | 0.947916 |
| SF9278 | 10 | 10 3/8 | 12 3/8 | 1.03125 |
| SF9279 | 11 | 11 3/8 | 13 3/8 | 1.114583 |
| SF9280 | 12 | 12 3/8 | 14 3/8 | 1.197916 |
| SF9281 | 13 | 13 3/8 | 15 3/8 | 1.28125 |
| SF9282 | 14 | 14 3/8 | 16 3/8 | 1.364583 |
| SF9283 | 15 | 15 3/8 | 17 3/8 | 1.447916 |
| SF9284 | 16 | 16 3/8 | 18 3/8 | 1.53125 |
| SF9285 | 17 | 17 3/8 | 19 3/8 | 1.614583 |
| SF9286 | 18 | 18 3/8 | 20 3/8 | 1.697916 |
| SF9287 | 19 | 19 3/8 | 21 3/8 | 1.78125 |
| SF9288 | 20 | 20 3/8 | 22 3/8 | 1.864583 |

| | | |
|--|------------------------|---|
| DRAWN JM | 4/18/2005 | cotterman co. 130 Seltzer Road, Croswell, Michigan, U.S.A., 48422 |
| CHECKED JK | 3/19/2013 | |
| APPROVED JK | 4/18/2005 | TITLE |
| PART SEE CHART | | STANDOFF BRACKETS BOLT-ON 4" (BLANKED & FORMED) |
| THIS PRINT IS PROPERTY OF COTTERMAN® CO., AND MAY NOT BE USED IN WHOLE OR PART WITHOUT WRITTEN PERMISSION. | | Drawing is computer generated, and print might not be to scale |
| SIZE B | DWG NO A0570151.dwg | REV C |
| DIMENSIONS IN INCHES UNLESS NOTED | | SHEET 1 OF 1 |

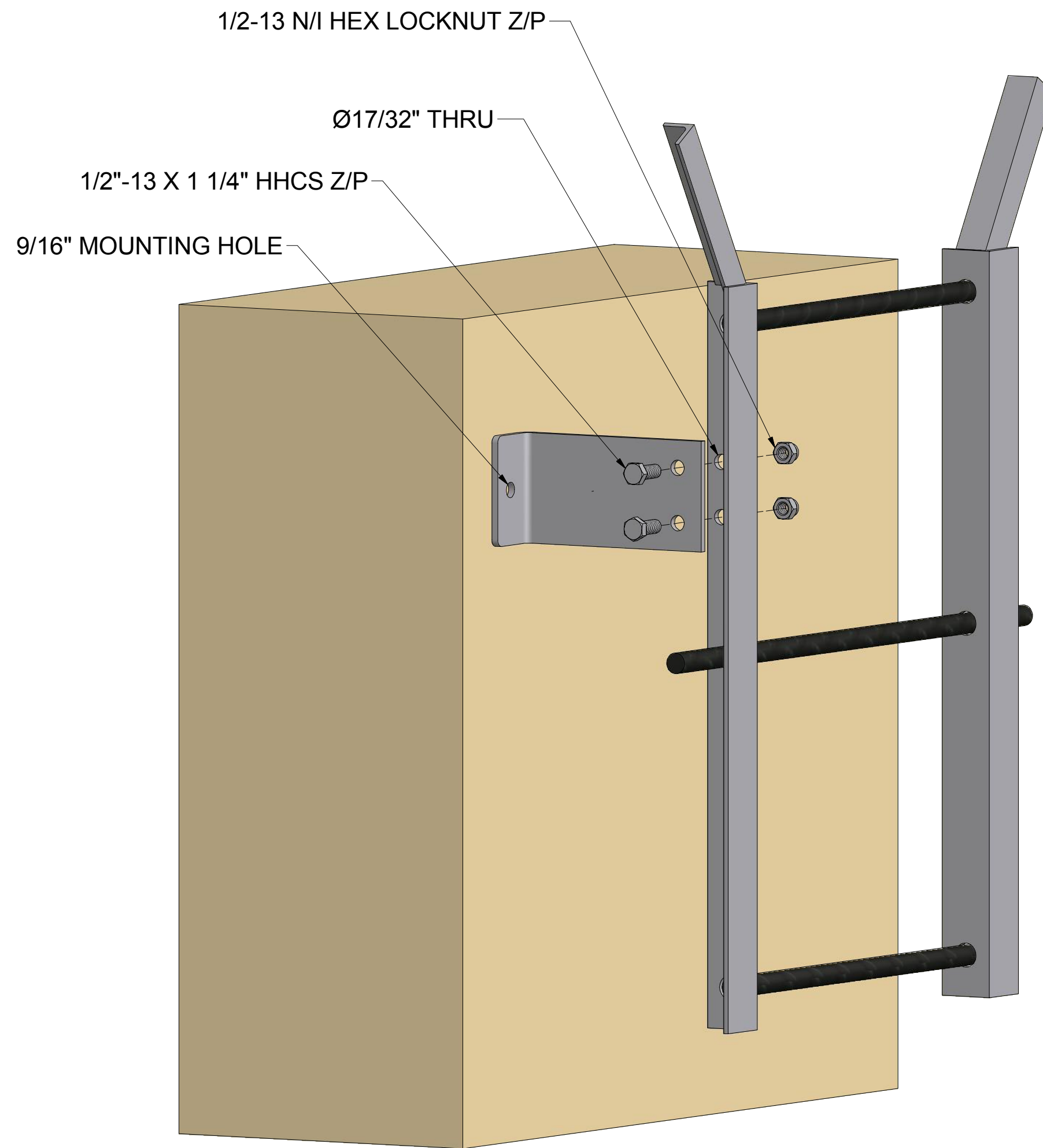

| | | | |
|--|----------|---|----------------|
| DRAWN DD | 8/3/2012 | cotterman. co. 130 Seltzer Road, Crosswell, Michigan, U.S.A., 48422 | |
| CHECKED | | TITLE | |
| APPROVED | | STANDOFF BRACKETS BOLT-ON MOUNTING DETAIL | |
| PART N/A | | Drawing is computer generated, and print might not be to scale | |
| THIS PRINT IS PROPERTY OF COTTERMAN® CO., AND MAY NOT BE USED IN WHOLE OR PART WITHOUT WRITTEN PERMISSION. | | SIZE | REV |
| | | C | D0570306PF.dwg |
| | | DIMENSIONS IN INCHES UNLESS NOTED | |
| | | SHEET 1 OF 1 | |